

# DH4 - DR4 1500 - 1700 - 2000 - 3000 AC - HYDRO

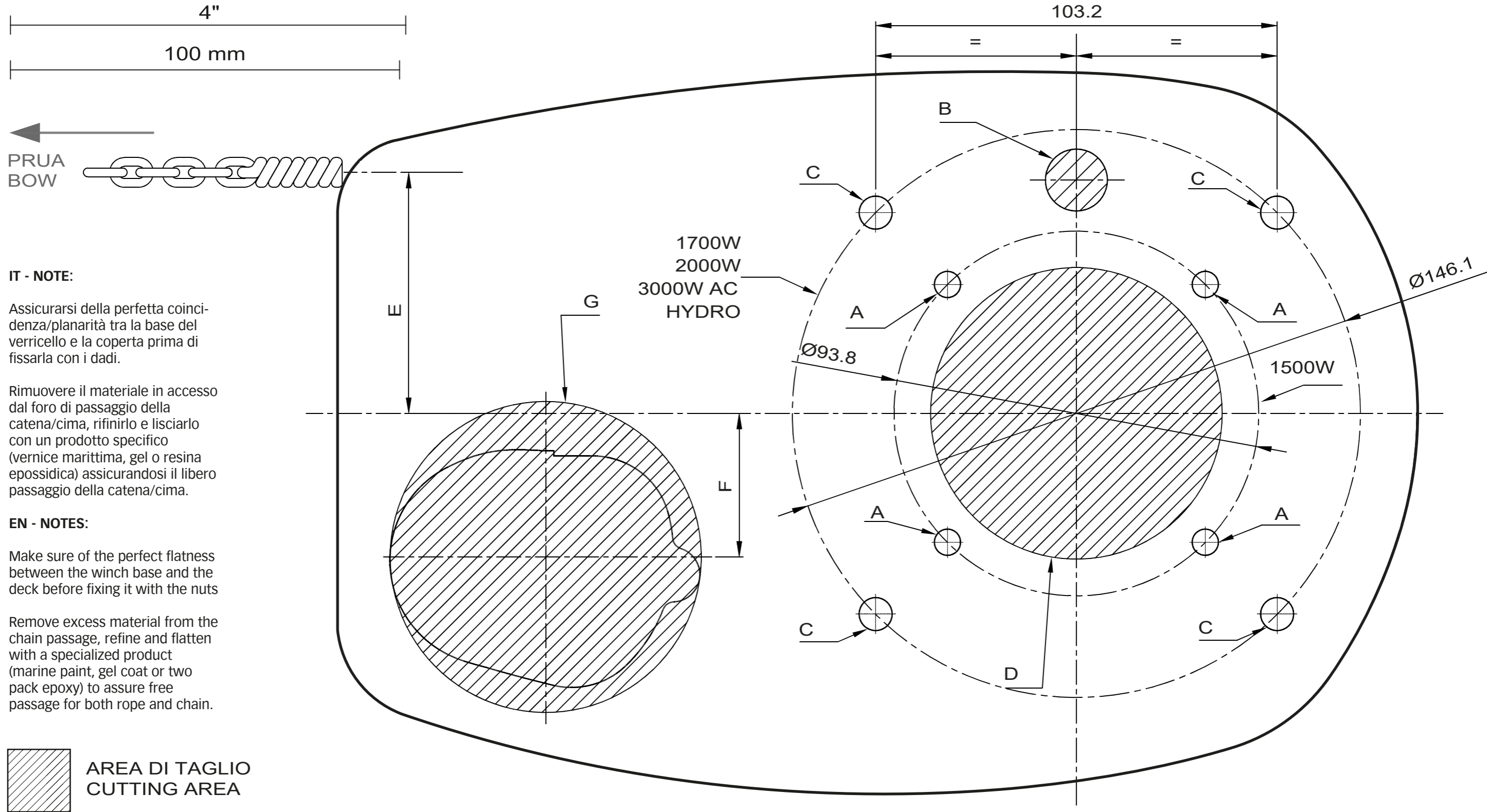

**IT - NOTE:**  
 Assicurarsi della perfetta coincidenza/planarità tra la base del verricello e la coperta prima di fissarla con i dadi.

Rimuovere il materiale in accesso dal foro di passaggio della catena/cima, rifinirlo e lisciarlo con un prodotto specifico (vernice marittima, gel o resina epossidica) assicurandosi il libero passaggio della catena/cima.

**EN - NOTES:**  
 Make sure of the perfect flatness between the winch base and the deck before fixing it with the nuts

Remove excess material from the chain passage, refine and flatten with a specialized product (marine paint, gel coat or two pack epoxy) to assure free passage for both rope and chain.

 **AREA DI TAGLIO CUTTING AREA**

	<b>A</b>	<b>B</b>	<b>C</b>	<b>D</b>	<b>E</b>	<b>F</b>	<b>G</b>
mm	Ø9	Ø16	Ø11	Ø80	62	278	Ø80
inc	Ø23/64	Ø 3/8	Ø7/16	Ø3"5/32	2"29/64	11"	Ø3"5/32

 NAUTICAL EQUIPMENT <small>Via Piangipane, 120/A - 48020 Piangipane (Ra) Italy.                  Telefono +39.0544.415061 - Fax +39.0544.415047</small>	Name <b>DRILLING TEMPLATE</b>		Rev. <input checked="" type="checkbox"/> 1 <input checked="" type="checkbox"/> 2 <input checked="" type="checkbox"/> 3 <input checked="" type="checkbox"/> 4
	Model DYLAN	Size A3	Scale 1:1
This is an unpublished work the copyright in which rest in Quick s.r.l. All this document and its information is supplied without liability for error or party may be reproduced used or disclosed except as authorized by contract or permission.		Drawing units	Date 12/02/09